



**STANDARD**

Performance Ka  
**Higher** Standard

# HEATING THAT DOESN'T KEEP YOU WAITING

Water heaters with super-quick heating



**WATER HEATER  
CATALOGUE 2025**

**RAISING CUSTOMER DELIGHT THROUGH HIGHER PERFORMANCE**

In the electrical industry, over the last 60 years, Standard Electricals has emerged as one of India's preferred brands.

Living up to its brand purpose—*Performance ka higher standard*—the business offers a wide range of technologically advanced products. From fans and water heaters to MCBs, RCCBs, distribution boards, modular switches, and copper flexible cables, every product reflects Standard's unwavering commitment to raising the bar of excellence.

To make these solutions accessible, Standard has developed an extensive network encompassing 3,000+ authorized dealers, 25+ exclusive brand stores, and 25,000+ retail outlets.

At the forefront of Standard's product evolution lies its Customer Experience & Designs (CXD) Studio, where creativity and user-centric design converge. This is complemented by its Centre for Research & Innovation (CRI), supported by four advanced R&D centres, enabling the business to consistently deliver products that are both functional and visually compelling.

Anchored in the 'Make in India' initiative, Standard operates five cutting-edge manufacturing facilities in Haridwar, Baddi, Sahibabad, Neemrana, and Alwar. Each product is rigorously tested to meet the highest safety and performance thresholds, ensuring the best quality.

Beyond its strong presence in the Indian market, Standard has also made a mark internationally. It has a significant presence in key SAARC nations, the Middle East, and African markets.

Driven by a commitment to innovation, quality, and design, Standard also upholds sustainable practices throughout its operations, including eco-friendly manufacturing processes and energy-efficient product design, contributing to a greener and more sustainable future.



CORPORATE OFFICE, NOIDA



State-of-the-Art Manufacturing Unit



Customer Experience & Design



Industry 4.0 Process



Center For Research & Innovation



Performance Ka **Higher** Standard

# NEEMRANA PLANT



**AUTOMATIC OUTER BODY ROLLING**  
 Most advanced outer body rolling with seamless welding system.  
 CNC controlled automatic punching machine.  
 Special purpose necking machine for precise bending.



**PORCO GLASS TECHNOLOGY**  
 Fully automatic shot blasting machine to remove impurities and oxides.  
 Swiss made fully automatic dry Porco glass coating machine.  
 Baking of coated tanks in PLC controlled, gas fired durance for fusion of glass and steel, 'ensuring longer life.'



**WELDING SHOP**  
 The best technologies from Japan ensure fool proof welding joints for years of trouble free service.  
 Welding of end caps and shells in an automatic MIG / Plasma welding line.  
 Each welded tank is tested for leakage at high pressure.



**PRESS SHOP**  
 Automatic Hydraulic Presses for deep drawing of steel sheets for making end covers of tanks.  
 Automatic Robots for loading and unloading of press machines.  
 Automatic System ensures high productivity and consistency in parts.



STORAGE PLASTIC | STORAGE METAL | INSTANT | IMMERSION RODS

# Plastic Storage Water Heaters



# DROID - M

**+ CONTEMPORARY DESIGN + ANTI-CORROSION TANK + 7 YEARS WARRANTY\***



With its unique hexagonal design, the Standard Droid-M not only enhances your bathroom's aesthetics but also makes efficient use of space due to its compact size.

Hexagon design adds a modern touch to the ambience

Porco glass coated inner tank protects against rust & corrosion to provide longer life

BEE 5-star rated product provides high energy savings



\*Warranty on inner tank | \*\*T&C apply

Capacity : 10 L, 15 L & 25 L

Color : White

## Technical dimensions in mm

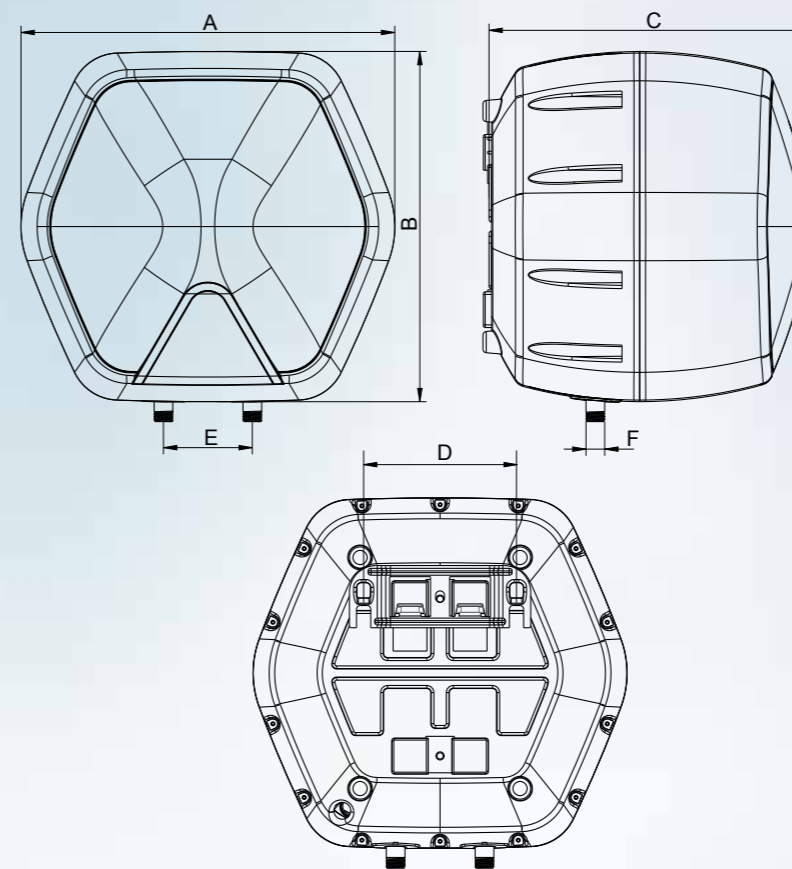

Model	A	B	C	D	E	F
10 L	421 mm	394 mm	302 mm	172 mm	100 mm	12.7 mm (G 1/2)
15 L	421 mm	394 mm	321 mm	172 mm	100 mm	12.7 mm (G 1/2)
25 L	491 mm	461 mm	408 mm	172 mm	100 mm	12.7 mm (G 1/2)

Note : All dimensions are in mm, dimensions tolerance  $\pm 5$  mm.



## Features



**Incoloy 800 heating element with enamel coating**  
Highly resistive to corrosion giving it a longer life



**Heavy duty protective anode**  
To help increase life of storage tank



**Durable inner tank**  
Single weld line tank made of ultra thick superior quality steel



**Inlet water tube with whirl flow**  
No immediate direct contact between cold and hot water for faster heating



**Dual safety feature**  
With automatic thermal cutoff & thermostat



**High density CFC free Polyurethane Foam (PUF) insulation**  
For energy efficiency and to store hot water for longer duration



**Adjustable thermostat**  
All weather temperature setting with maximum temperature of 75 °C



**Multi functional safety valve**  
For protection against excessive pressure (upto 8 bar), ideal for high rise buildings

# GLAZER

**+ CONTEMPORARY DESIGN + ANTI-CORROSION TANK + 7 YEARS WARRANTY\***



The distinctive square design of Standard Glazer elevates bathroom décor and fits seamlessly into compact spaces.

Square design adds a modern touch to the ambience

Porco glass coated inner tank protects against rust & corrosion to provide longer life

BEE 5-star rated product provides high energy savings



**PORCO GLASS™  
TECHNOLOGY**



**PRECISE  
TEMPERATURE  
CONTROL**



**FREE  
FLEXI PIPES\*\***

\*Warranty on inner tank | \*\*T&C apply

Capacity : 10 L, 15 L & 25 L  
Color : Grey, Blue & Brown

## Technical dimensions in mm

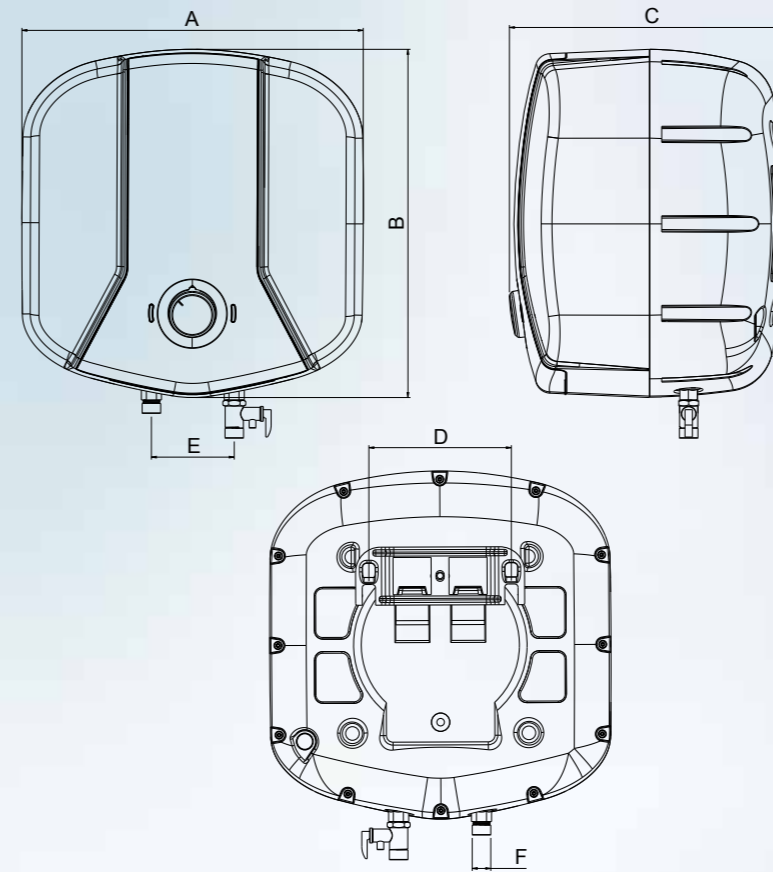

Model	A	B	C	D	E	F
10 L	412 mm	420 mm	280 mm	172 mm	100 mm	21 mm (G 1/2)
15 L	412 mm	420 mm	340 mm	172 mm	100 mm	21 mm (G 1/2)
25 L	466 mm	476 mm	385 mm	68 mm	100 mm	21 mm (G 1/2)

Note : All dimensions are in mm, dimensions tolerance ± 5 mm.



## Features



**Trio core heating element**  
Highly resistive to corrosion giving it a longer life



**Dual safety feature**  
With automatic thermal cutoff & thermostat



**Heavy duty protective anode**  
To help increase life of Storage Tank



**High density CFC free Polyurethane Foam (PUF) insulation**  
For energy efficiency and to store hot water for longer duration



**Durable steel tank**  
Single weld line tank made of ultra thick superior quality steel



**Adjustable thermostat**  
All weather temperature setting with maximum temperature of 75 °C



**Inlet water tube with whirl flow**  
No immediate direct contact between cold and hot water for faster heating



**Multi functional safety valve**  
For protection against excessive pressure (upto 8 bar), ideal for high rise buildings

# Ripple

**+ ANTI-CORROSION TANK + 7 YEARS WARRANTY\* + PRECISE TEMPERATURE CONTROL**

**NEW**



Built with Porco Glass Technology, bring home the long-lasting Ripple water heaters.

Porco glass coating on the storage tank for longer life

Multi-functional safety valve for protection against excessive pressure

Innovative whirl flow technology for quick heating

Heavy duty protective anode



\*Warranty on inner tank | \*\*T&C apply

Capacity : 10 L, 15 L & 25 L  
Colors : Dark Grey & Light Grey



## Technical dimensions in mm

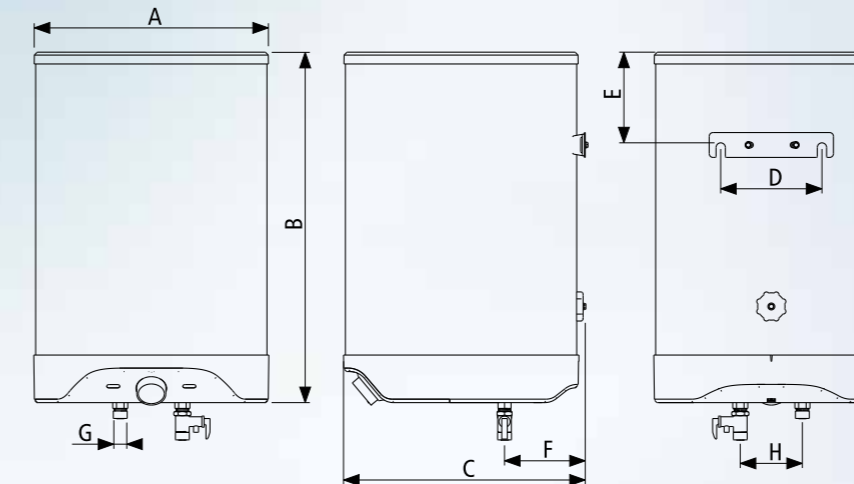

Model	A	B	C	D	E	F	G	H
10 L	327 mm	424 mm	336 mm	163 mm	154 mm	102 mm	12.7 mm (G 1/2)	100 mm
15 L	327 mm	524 mm	336 mm	163 mm	153 mm	102 mm	12.7 mm (G 1/2)	100 mm
25 L	377 mm	564 mm	389 mm	163 mm	146 mm	130 mm	12.7 mm (G 1/2)	100 mm

Note : All dimensions are in mm, dimensions tolerance  $\pm 5$  mm.

## Features

- Trio core heating element**  
Highly resistive to corrosion giving it a longer life
- Heavy duty protective anode**  
To help increase life of Storage Tank
- Dual safety feature**  
With automatic thermal cutoff & thermostat
- Adjustable thermostat**  
All weather temperature setting with maximum temperature of 75 °C
- Inlet water tubes with whirl flow**  
No immediate direct contact between cold and hot water for faster heating
- High density CFC free Polyurethane Foam (PUF) insulation**  
For energy efficiency and to store hot water for longer duration
- Multi functional safety valve**  
For protection against excessive pressure (upto 8 bar), ideal for high rise buildings
- Durable inner tank**  
Single weld line tank made of ultra thick superior quality steel

# AMEO

**+ ANTI-CORROSION TANK + 7 YEARS WARRANTY\* + PRECISE TEMPERATURE CONTROL**



Bring home lasting warmth with the Standard Ameo water heater, built tough with Porco Glass Technology.

Porco glass coating on the storage tank for longer life

Multi-functional safety valve for protection against excessive pressure

Innovative whirl flow technology for quick heating

Heavy duty protective anode



**PRECISE TEMPERATURE CONTROL**



**FREE FLEXI PIPES\*\***

\*Warranty on inner tank | \*\*T&C apply



Capacity : 10 L, 15 L & 25 L  
Colors : White Blue & Ivory Red

## Technical dimensions in mm

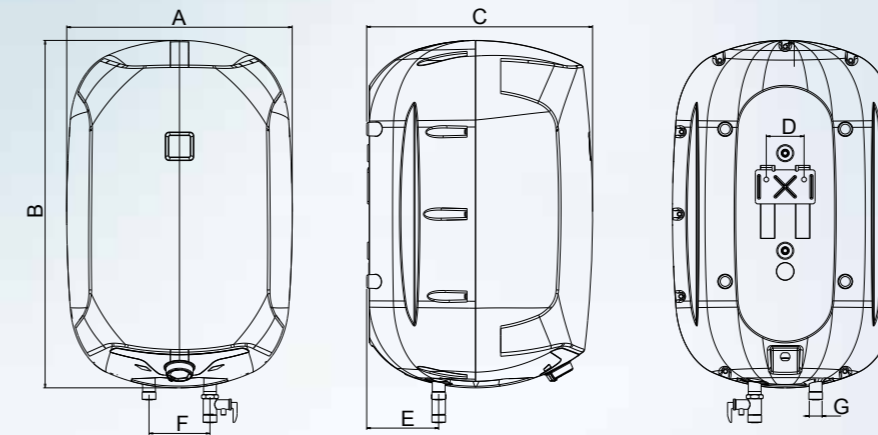

Model	A	B	C	D	E	F	G
10 L	318 mm	462 mm	302 mm	62 mm	79 mm	110 mm	12.7 mm (G 1/2)
15 L	330 mm	485 mm	321 mm	62 mm	94 mm	100 mm	12.7 mm (G 1/2)
25 L	370 mm	570 mm	371 mm	62 mm	118 mm	100 mm	12.7 mm (G 1/2)

Note : All dimensions are in mm, dimensions tolerance  $\pm 5$  mm.

## Features



**Incoloy 800 heating element with enamel coating**  
Highly resistive to corrosion giving it a longer life



**Heavy duty protective anode**  
To help increase life of Storage Tank



**Dual safety feature**  
With automatic thermal cutoff & thermostat



**Adjustable thermostat**  
All weather temperature setting with maximum temperature of 75 °C



**Inlet water tubes with whirl flow**  
No immediate direct contact between cold and hot water for faster heating



**High density CFC free Polyurethane Foam (PUF) insulation**  
For energy efficiency and to store hot water for longer duration



**Multi functional safety valve**  
For protection against excessive pressure (upto 8 bar), ideal for high rise buildings



**Durable inner tank**  
Single weld line tank made of ultra thick superior quality steel

# LYFT - 6 L

**+ ANTI-CORROSION TANK + RUST PROOF OUTER BODY + 7 YEARS WARRANTY\***



Elevate your bathroom and kitchen aesthetics with the sleek, minimalist Standard Lyft.

Single weld line tank made of ultra-thick superior cold rolled steel

High Precision Pre-calibrated Thermostat to help increase life of heating element



**PORCO GLASS™ TECHNOLOGY**



**FREE FLEXI PIPES\*\***

\*Warranty on inner tank | \*\*T&C apply

Capacity : 6 L  
Color : White



## Technical dimensions in mm

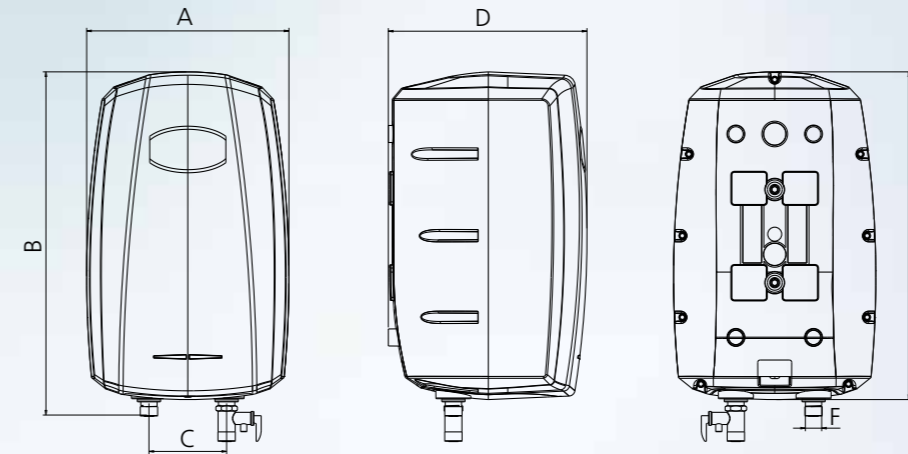

Model	A	B	C	D	E	F
6 L	260 mm	442 mm	100 mm	256 mm	422 mm	12.7 mm (G 1/2)

Note : All dimensions are in mm, dimensions tolerance  $\pm 5$  mm.

## Features



**Incoloy 800 heating element with enamel coating**  
Highly resistive to corrosion giving it a longer life



**Durable inner tank**  
Single weld line tank made of ultra thick superior quality steel



**Dual safety feature**  
With automatic thermal cutoff & thermostat



**High precision pre-calibrated thermostat**  
To help increase life of heating element



**Heavy duty protective anode**  
To help increase life of Storage Tank



**Rust proof body**  
High quality ABS outer body



**High density CFC free Polyurethane Foam (PUF) insulation**  
For energy efficiency and to store hot water for longer duration



**Multi functional safety valve**  
For protection against excessive pressure (upto 8 bar), ideal for high rise buildings

# Metal Storage Water Heaters



# PLASH

**+ PORCO GLASS TECHNOLOGY + ANTI-CORROSION TANK + 7 YEARS WARRANTY\***



Enjoy lasting performance with the Standard Plash, built with Porco Glass Technology and a heavy-duty protective anode.

Innovative whirl flow technology for quicker heating

Multi-functional safety valve for protection against excessive pressure

Preset thermal cut-out



**PORCO GLASS™ TECHNOLOGY**



**PRECISE TEMPERATURE CONTROL**

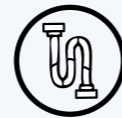

**FREE FLEXI PIPES\*\***

\*Warranty on inner tank | \*\*T&C apply

Capacity : 10 L, 15 L & 25 L

Colors : White



## Technical dimensions in mm

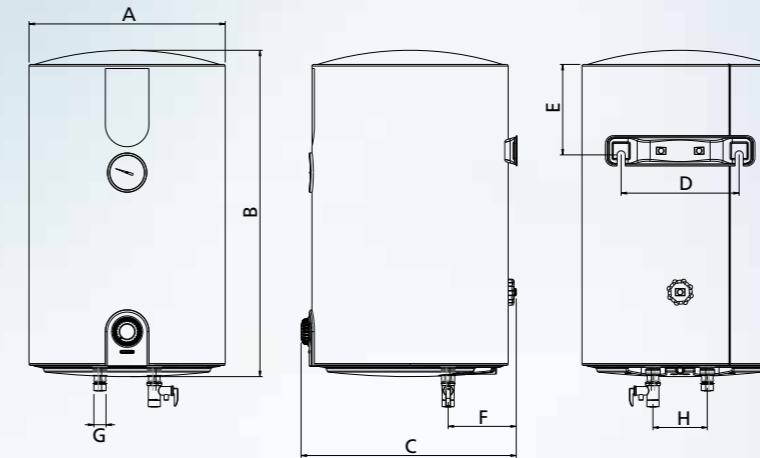

Model	A	B	C	D	E	F	G	H
10 L	311 mm	445 mm	342 mm	163 mm	162 mm	101 mm	21 mm (G1/2)	100 mm
15 L	311 mm	540 mm	342 mm	163 mm	162 mm	101 mm	21 mm (G1/2)	100 mm
25 L	361 mm	600 mm	394 mm	163 mm	166 mm	125 mm	21 mm (G1/2)	100 mm

Note : All dimensions are in mm, dimensions tolerance ± 5 mm.

## Features



**Trio core heating element**  
Highly resistive to corrosion giving it a longer life



**Dual safety feature**  
With automatic thermal cutoff & thermostat



**Heavy duty protective anode**  
To help increase life of Storage Tank



**High density CFC free Polyurethane Foam (PUF) insulation**  
For energy efficiency and to store hot water for longer duration



**Durable steel tank**  
Single weld line tank made of ultra thick superior quality steel



**Adjustable thermostat**  
All weather temperature setting with maximum temperature of 75 °C



**Inlet water tube with whirl flow**  
No immediate direct contact between cold and hot water for faster heating



**Multi functional safety valve**  
For protection against excessive pressure (upto 8 bar), ideal for high rise buildings

# AMAZE PLUS

**+ DUAL SAFETY MECHANISM + ANTI-CORROSION TANK + 7 YEARS WARRANTY\***

**NEW**



Designed with a striking new decal, the tough Standard Amaze Plus is both beautiful and durable.

Innovative whirl flow technology for quicker heating

Multi-functional safety valve for protection against excessive pressure

Preset thermal cut-out

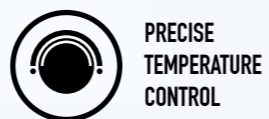

\*Warranty on inner tank | \*\*T&C apply



Capacity : 10 L, 15 L, & 25 L  
Colors : White

## Technical dimensions in mm

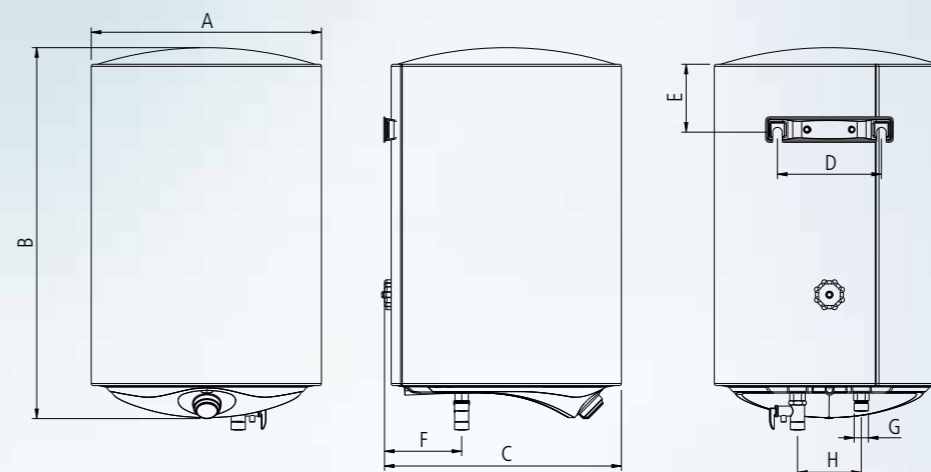

Model	A	B	C	D	E	F	G	H
10 L	308 mm	422 mm	318 mm	163 mm	112 mm	101 mm	12.7 mm (G1/2)	100 mm
15 L	308 mm	517 mm	318 mm	163 mm	112 mm	101 mm	12.7 mm (G1/2)	100 mm
25 L	358 mm	581 mm	368 mm	163 mm	116 mm	125 mm	12.7 mm (G1/2)	100 mm

Note : All dimensions are in mm, dimensions tolerance  $\pm 5$  mm.

## Features



**Trio core heating element**  
Highly resistive to corrosion giving it a longer life



**Heavy duty protective anode**  
To help increase life of Storage Tank



**Durable steel tank**  
Single weld line tank made of ultra thick superior quality steel



**Inlet water tube with whirl flow**  
No immediate direct contact between cold and hot water for faster heating



**Dual safety feature**  
With automatic thermal cutoff & thermostat



**High density CFC free Polyurethane Foam (PUF) insulation**  
For energy efficiency and to store hot water for longer duration



**Adjustable thermostat**  
All weather temperature setting with maximum temperature of 75 °C



**Multi functional safety valve**  
For protection against excessive pressure (upto 8 bar), ideal for high rise buildings

# GLITZR

**+ CONTEMPORARY DESIGN + ANTI-CORROSION TANK + 5 YEARS WARRANTY\***

**NEW**



Standard Glitzr's compact design makes your bathroom both spacious and stylish.

Cylindrical design adds a modern touch to the ambience

Hydro guard coated inner tank protects against rust & corrosion to provide longer life

BEE 4-star rated product provides high energy savings



**HYDRO GUARD COATING**



**PRECISE TEMPERATURE CONTROL**



**FREE FLEXI PIPES\*\***

\*Warranty on inner tank | \*\*T&C apply

Capacity : 10 L, 15 L & 25 L

Colors : White



## Technical dimensions in mm

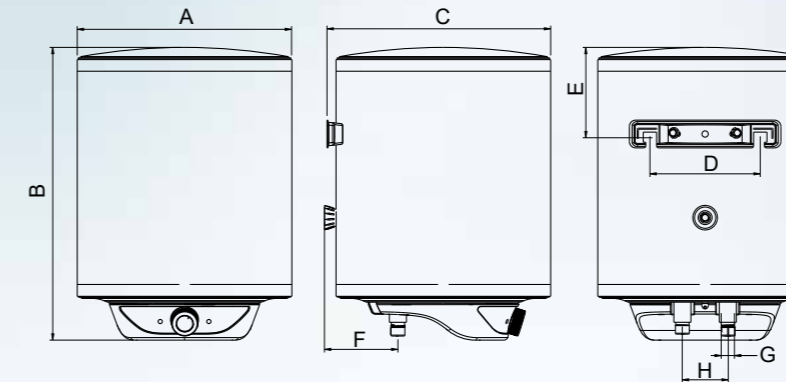

Model	A	B	C	D	E	F	G	H
10 L	340 mm	320 mm	360 mm	175 mm	102 mm	118 mm	12.7 mm (G 1/2)	72 mm
15 L	340 mm	432 mm	360 mm	175 mm	130 mm	118 mm	12.7 mm (G 1/2)	72 mm
25 L	355 mm	506 mm	375 mm	175 mm	136 mm	118 mm	12.7 mm (G 1/2)	72 mm

Note : All dimensions are in mm, dimensions tolerance  $\pm 5$  mm.

## Features



**Trio core heating element**  
Highly resistive to corrosion giving it a longer life



**Dual safety feature**  
With automatic thermal cutoff & thermostat



**Heavy duty protective anode**  
To help increase life of Storage Tank



**High density CFC free Polyurethane Foam (PUF) insulation**  
For energy efficiency and to store hot water for longer duration



**Durable steel tank with hydro guard coating**  
Single weld line tank made of ultra thick superior quality steel



**Temperature control knob**  
All weather temperature setting with maximum temperature of 75 °C



**Inlet water tube with whirl flow**  
No immediate direct contact between cold and hot water for faster heating



**Multi functional safety valve**  
For protection against excessive pressure (upto 8 bar), ideal for high rise buildings

# AMAZER PLUS

**+ QUICK HEATING TECHNOLOGY + ANTI-CORROSION TANK + 7 YEARS WARRANTY\***



Bring home the strength of the Amazer Plus, engineered for durability with a heavy-duty protective anode.

Innovative Whirl Flow Technology for quicker heating

Multi-functional safety valve for protection against excessive pressure

Preset thermal cut-out



\*Warranty on inner tank | \*\*T&C apply

Capacity : 35 L & 50 L  
Colors : White



## Technical dimensions in mm

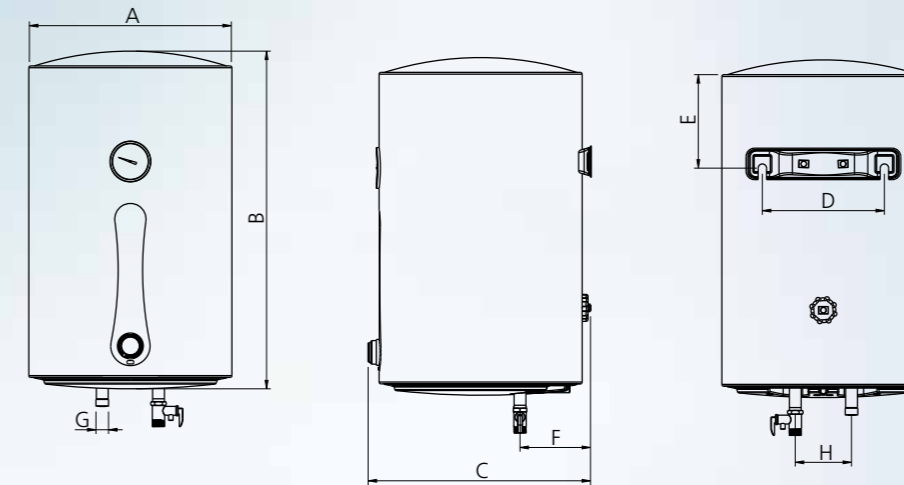

Model	A	B	C	D	E	F	G	H
35 L	411 mm	620 mm	444 mm	217 mm	192.5 mm	97 mm	21 mm	100 mm
50 L	461 mm	643 mm	494 mm	217 mm	172 mm	97 mm	21 mm	100 mm

Note : All dimensions are in mm, dimensions tolerance  $\pm 5$  mm.

## Features



**Incoloy 800 heating element with enamel coating**  
Highly resistive to corrosion giving it a longer life



**Heavy duty protective anode**  
To help increase life of Storage Tank



**Durable inner tank**  
Single weld line tank made of ultra thick superior quality steel



**Inlet water tubes with whirl flow**  
No immediate direct contact between cold and hot water for faster heating



**Dual safety feature**  
With automatic thermal cutoff & thermostat



**High density CFC free Polyurethane Foam (PUF) insulation**  
For energy efficiency and to store hot water for longer duration



**Adjustable thermostat**  
All weather temperature setting with maximum temperature of 75 °C



**Multi functional safety valve**  
For protection against excessive pressure (upto 8 bar), ideal for high rise buildings

# AMAZER-H

**+ COMPACT DESIGN + REVERSIBLE OPERATION + 7 YEARS WARRANTY\***

Capacity : 10 L, 15 L & 25 L  
Color : White Blue



Designed for your convenience, the Standard Amazer-H is available in both right and left orientations.

Longer life with Incoloy 800 heating element with enamel coating to resist corrosion  
Multi-functional safety valve for protection against excessive pressure



\*Warranty on inner tank | \*\*T&C apply

## Technical dimensions in mm

Right hand side inlet outlet

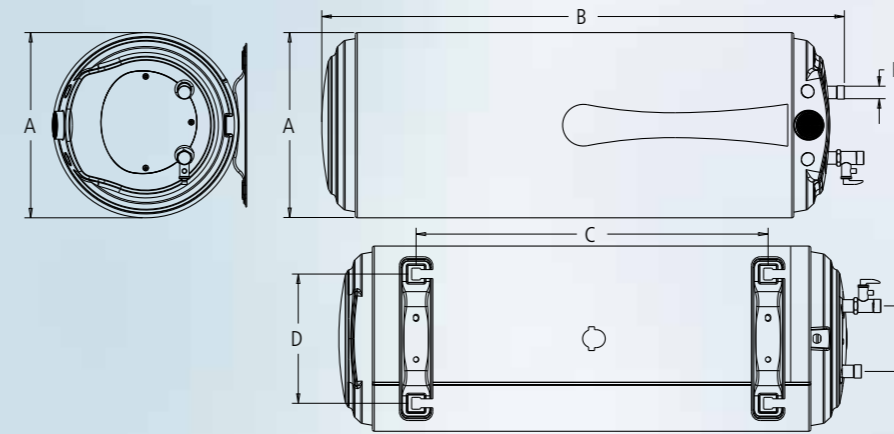

Left hand side inlet outlet

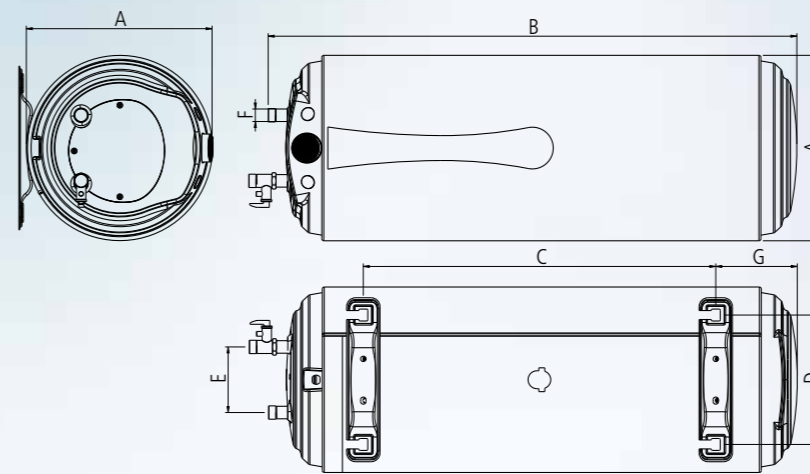

Model	A	B	C	D	E	F	G
10 L	311 mm	473 mm	190 mm	217 mm	110 mm	12.7 mm (G 1/2)	130 mm
15 L	311 mm	602 mm	320 mm	217 mm	110 mm	12.7 mm (G 1/2)	130 mm
25 L	311 mm	875 mm	591 mm	217 mm	110 mm	12.7 mm (G 1/2)	130 mm

Note : All dimensions are in mm, dimensions tolerance  $\pm 5$  mm.



## Features



**Incoloy 800 heating element with enamel coating**  
Highly resistive to corrosion giving it a longer life



**Dual safety feature**  
With automatic thermal cutoff & thermostat



**Heavy duty protective anode**  
To help increase life of Storage Tank



**High density CFC free Polyurethane Foam (PUF) insulation**  
For energy efficiency and to store hot water for longer duration



**Durable inner tank**  
Single weld line tank made of ultra thick superior quality steel



**Adjustable thermostat**  
All weather temperature setting with maximum temperature of 75 °C



**Inlet water tube with whirl flow**  
No immediate direct contact between cold and hot water for faster heating



**Multi functional safety valve**  
For protection against excessive pressure (upto 8 bar), ideal for high rise buildings

# Instant Water Heaters

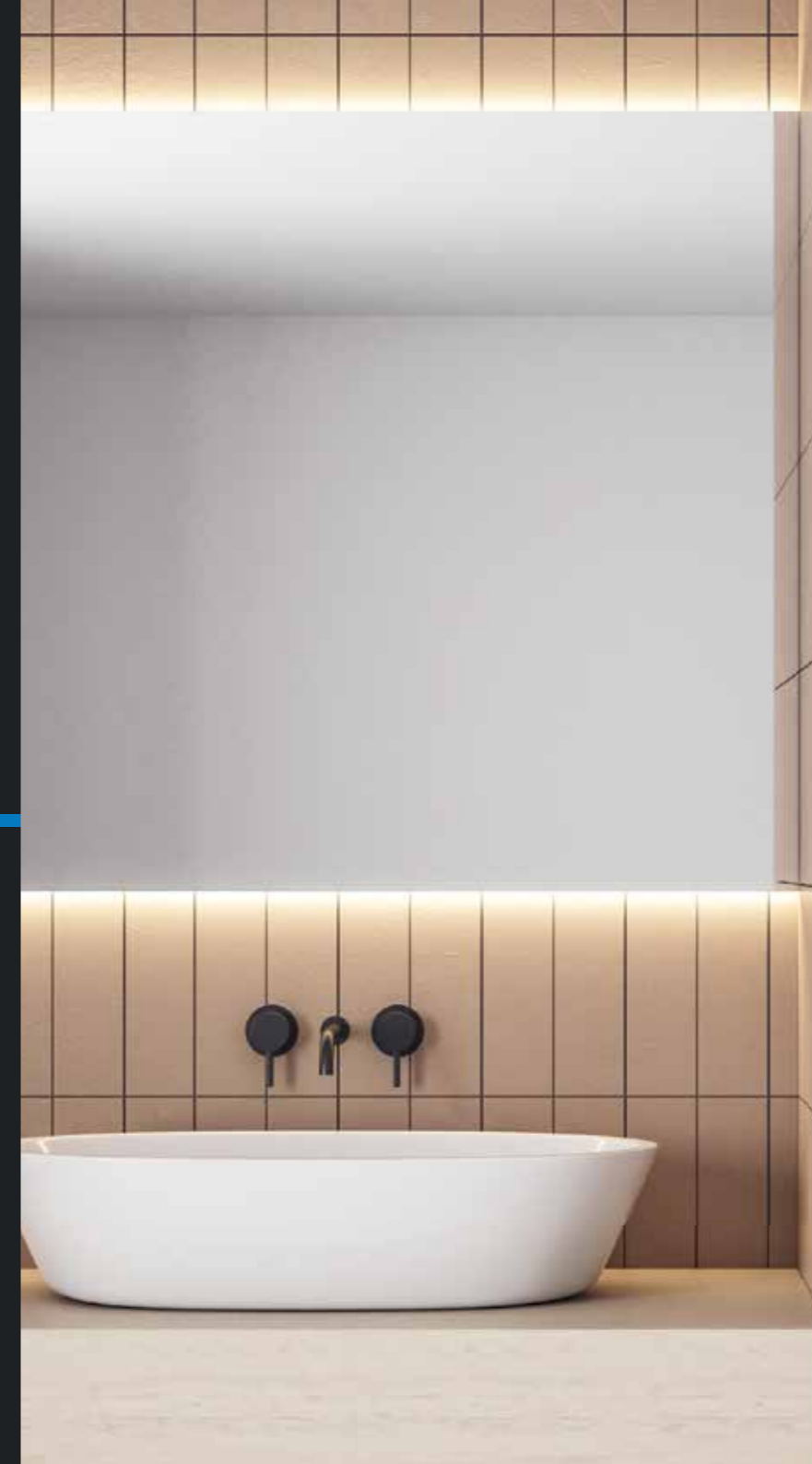

# Alina

**+ COMPACT DESIGN + HEAVY DUTY COPPER ELEMENT + 5 YEARS WARRANTY\***

Coming Soon



Transform your space with the compact and effective Standard Alina water heater.

Innovative compact design for easy installation

Superior 304 L grade stainless steel ultra-thick tank

Rust proof high quality outer body



**SUPERIOR  
GRADE  
SS TANK**



**HIGH  
PRESSURE  
SAFETY  
VALVE**

\*Warranty on inner tank | T&C apply

Capacity : 5 L  
Color : Grey



## Technical dimensions in mm

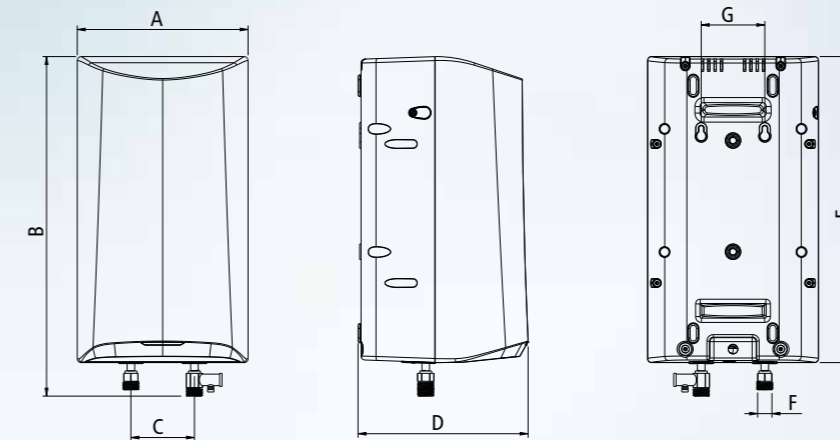

Model	A	B	C	D	E	F	G
5 L	215 mm	430 mm	80 mm	215 mm	385 mm	12.7 mm (G 1/2)	80 mm

Note : All dimensions are in mm, dimensions tolerance  $\pm 5$  mm.

## Features



**Stainless steel tank**  
Ultra thick & superior grade SS tank



**Heavy duty**  
Copper heating element



**Multi functional safety valve**  
For protection against excessive pressure (upto 6.5 bar), ideal for high rise buildings



**LED indicator**



**Plastic outer body**  
High quality plastic outer body



**Dual safety feature**  
With automatic thermal cutoff & thermostat



**Fire retardant power cord**  
For safety & protection

Instant Water Heater

# CALOR

**+ COMPACT DESIGN + HEAVY DUTY COPPER ELEMENT + 5 YEARS WARRANTY\***



Flaunt your style with the smart and stylish Standard Calor water heater.

Innovative compact design for easy installation

Superior 304 L grade stainless steel ultra-thick tank

Rust proof high quality outer body



\*Warranty on inner tank | T&C apply

Capacity : 3 L & 5 L  
Color : White



## Technical dimensions in mm

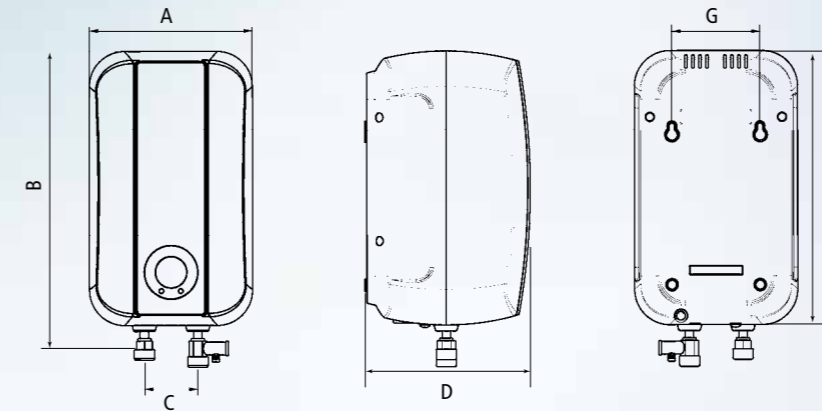

Model	A	B	C	D	E	F	G
3 L	185 mm	337 mm	60.5 mm	187.5 mm	310 mm	12.5 mm (G 1/2)	100 mm
5 L	210 mm	430 mm	60.5 mm	210 mm	380 mm	12.5 mm (G 1/2)	120 mm

Note : All dimensions are in mm, dimensions tolerance  $\pm 5$  mm.

## Features



**Stainless steel tank**  
Ultra thick & superior grade SS tank



**Rust proof body**  
High quality outer body



**Safety valve (upto 6.5 bar)**  
Protection against excessive pressure & ideal for high rise building



**High precision pre-calibrated thermostat**  
To help increase life of heating element



**Preset thermal cutout**  
Automatic cut out on high & unsafe temperature



**Fire retardant power cord**  
For safety & protection

# Immersion Rods



# ETNA PRO

**+ MODERN DESIGN + NEON LED INDICATOR + 2 YEARS WARRANTY\***

**NEW**





Compact design, powerful heating — the efficient Standard Etna Pro immersion rods deliver quick results.

Modern design with nickel plating on heating element

High temperature resistance bakelite cover

ISI mark, 3 Pin moulded plug

Flame retardant power cord

IS : 368  CM/L-8155069	SAFETY  IS : 302-2-201 CM/L-8155170
<b>MADE IN INDIA</b>	

<b>2 YEARS WARRANTY</b>	<b>1500 W</b>	<b>1000 W</b>
-------------------------	---------------	---------------

\*T&C apply

Capacity : 1000 W & 1500 W  
Color : Blue



## Technical dimensions in mm

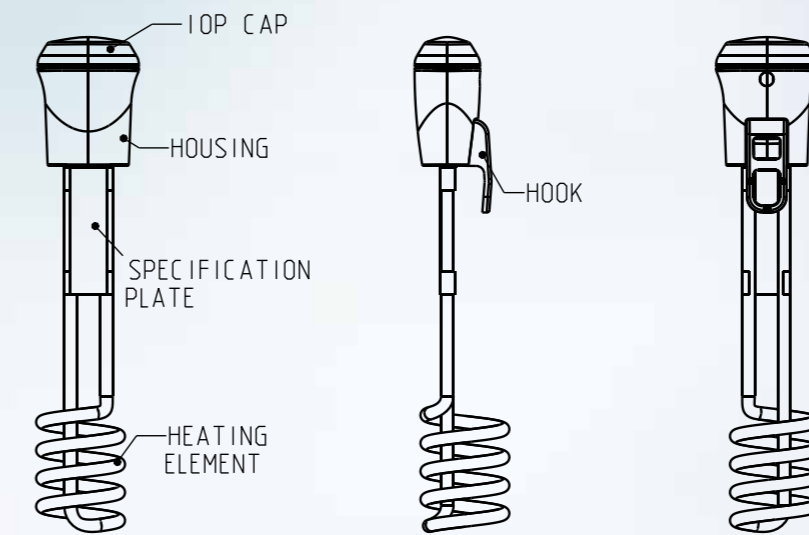

## Features

-  High temp. resistance bakelite cover
-  ISI mark 3 pin moulded plug
-  Elegant and sturdy bucket hook
-  Flame retardant power cord
-  Nickel plating for corrosion resistance
-  Shockproof immersion
-  Durable long lasting heating element

## PRODUCT KNOWLEDGE



## GUIDE TO WATER HEATER SELECTION

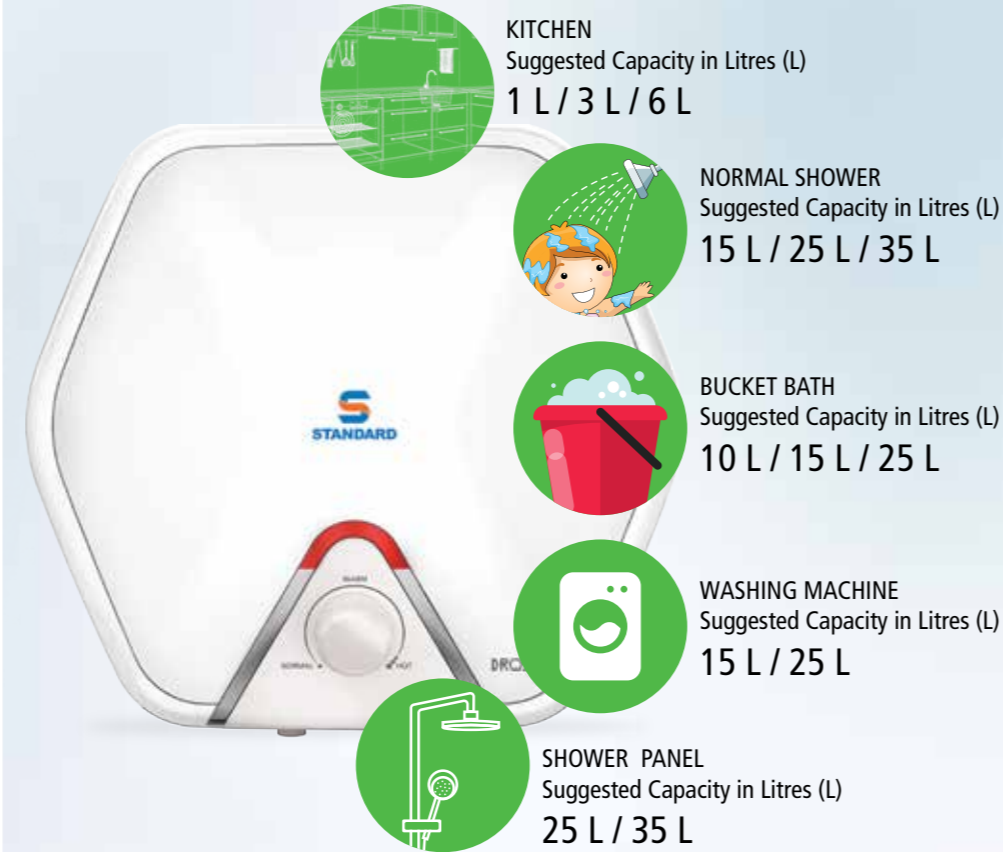

## SPECIFICATION SHEET



Rated Capacity in Litre	DROID-M			GLAZER			RIPPLE			AMEO			LYFT	PLASH			AMAZE PLUS			GLITZR		AMAZER PLUS		AMAZER - H			ALINA	CALOR			
	10 L	15 L	25 L	10 L	15 L	25 L	10 L	15 L	25 L	10 L	15 L	25 L	6 L	10 L	15 L	25 L	10 L	15 L	25 L	10 L	15 L	25 L	35 L	50 L	10 L	15 L	25 L	5 L	3 L	5 L	
Mounting	Vertical			Vertical			Vertical			Vertical			Vertical	Vertical			Vertical			Vertical		Horizontal			Vertical	Vertical					
Rated Voltage (V) & frequency (Hz)	230 V / 50 Hz			230 V / 50 Hz			230 V / 50 Hz			230 V / 50 Hz			230 V / 50 Hz	230 V / 50 Hz			230 V / 50 Hz			230 V / 50 Hz		230 V / 50 Hz		230 V / 50 Hz			230 V / 50 Hz	230 V / 50 Hz			
Rated Power Input (W)	2000 W			2000 W			2000 W			2000 W			3000 W	2000 W			2000 W			2000 W		2000 W		2000 W			3000 W	3000 W	4500 W	3000 W	
Rated Current (A)	8.7 A			8.7 A			8.7 A			8.7 A			16 A	8.7 A			8.7 A			8.7 A		8.7 A		8.7 A			16 A	16 A	24 A	16 A	
Max Hot Water Output Temp. (°C)	75 °C			75 °C			75 °C			75 °C			75 °C	75 °C			75 °C			55 °C		75 °C		75 °C			55 °C	75 °C			
Rated Pressure in MPa	0.8 MPa			0.8 MPa			0.8 MPa			0.8 MPa			0.8 MPa	0.8 MPa			0.8 MPa			0.8 MPa		0.8 MPa		0.8 MPa			0.65 MPa	0.65 MPa			
Standing Loss in kWh / 24 h / 45 °C	0.332 kWh	0.381 kWh	0.465 kWh	0.332 kWh	0.381 kWh	0.465 kWh	0.332 kWh	0.381 kWh	0.465 kWh	0.365 kWh	0.419 kWh	0.511 kWh	0.291 kWh	0.332 kWh	0.381 kWh	0.465 kWh	0.365 kWh	0.419 kWh	0.511 kWh	0.365 kWh	0.419 kWh	0.511 kWh	0.584 kWh	0.675 kWh	0.365 kWh	0.419 kWh	0.511 kWh	NA	NA	NA	
Reheating Time in minutes to raise 50 °C (min)	19 min	30 min	60 min	15 min	23 min	43 min	20 min	30 min	45 min	15 min	20 min	35 min	11 min	15 min	23 min	43 min	15 min	23 min	43 min	20 min	35 min	50 min	80 min	95 min	15 min	20 min	35 min	NA	NA	NA	
<b>Weight of water heater (in kg)</b>																															
Water Filled (kg)	19.2 kg	25.15 kg	38.3 kg	21.1 kg	27.7 kg	41.1 kg	16.8 kg	24.2 kg	36.5 kg	18.2 kg	24.3 kg	36.8 kg	12.4 kg	21.1 kg	27.7 kg	41.1 kg	21.1 kg	27.7 kg	41.1 kg	17 kg	23.9 kg	31 kg	52.8 kg	71 kg	19.4 kg	26.6 kg	41 kg	7.85 kg	5.2 kg	7.85 kg	
Water proof degree	IP X 4			IP X 4			IP X 4			IP X 4			IP X 4	IP X 4			IP X 4			IP X 4		IP X 4		IP X 4			IP X 4	IP X 4			
Class of appliance	Class I			Class I			Class I			Class I			Class I	Class I			Class I			Class I		Class I		Class I			Class I	Class I			
Star Rating	5 star			5 star			5 star			4 Star			4 Star	5 Star			4 star			4 Star		4 star		4 star			NA	NA			
Product Warranty	2 years			2 years			2 years			2 years			2 years	2 years			2 years			2 years		2 years		2 years			2 years	2 years			
Heating Element Warranty	4 years			4 years			4 years			4 years			4 years	4 years			4 years			4 years		4 years		4 years			4 years	4 years			
Tank Warranty	7 years			7 years			7 years			7 years			7 years	7 years			7 years			5 years		7 years		7 years			5 years	5 years			

NOTES

NOTES

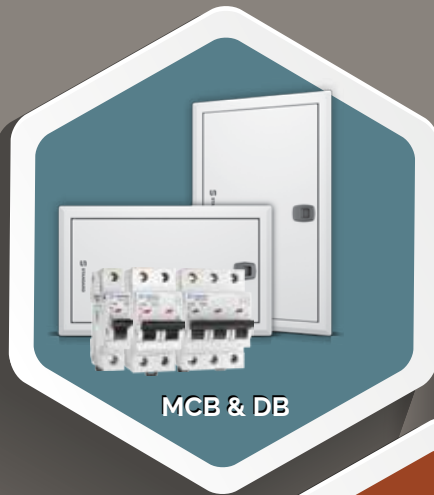

MCB & DB

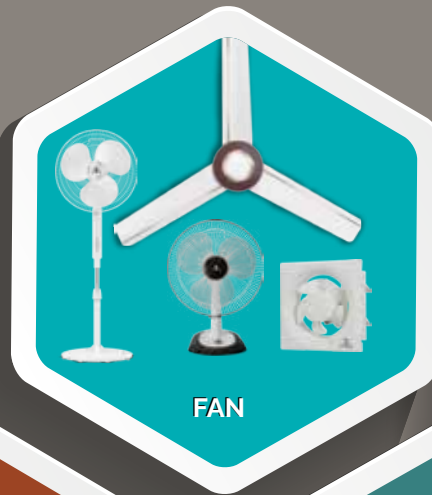

FAN



WIRE & CABLE

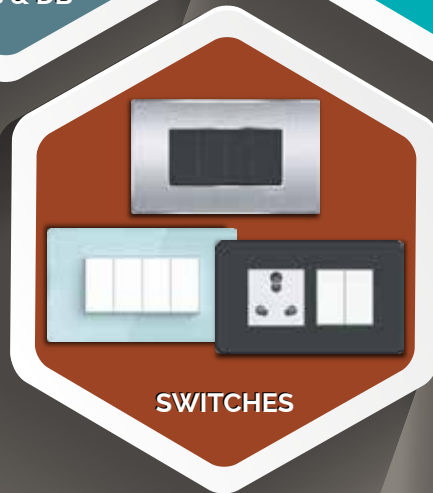

SWITCHES



WATER HEATER

## Havells India Ltd.

Corp Office: QRG Towers, 2D, Sector-126, Expressway, Noida-201304 (U.P),  
Ph. +91-120-3331000, E-mail: standard.ho@havells.com, www.standardelectricals.com

Customer Care No. 08045 77 1313

CIN - L31900DL1983PLC016304.

Copyright Subsists. Imitation of trade dress, graphics and color scheme of this document is a punishable offence.

Actual products may vary in colour, design, description and colour combination etc. Although every effort has been made to ensure accuracy in the compilation of the technical detail within this publication. Specifications & performance data are constantly changing.

